

# Owner's Manual

Read and keep this manual.  
Patents World Wide



S & S Industries, Inc., Sarasota, FL, USA  
www.trail-gator.com  
Copyright 2008 All Rights Reserved



The following manual is provided to assist in the assembly, maintenance, service, safe operation, and warranty of the Trail-Gator Bicycle Tow Bar. Failure of the owner or operator to read, understand and follow everything contained in this Owner's Manual can result in serious personal injury and death. Proper assembly, maintenance, and operation of the child bike, adult bike, and Trail-Gator Bicycle Tow Bar is your responsibility. S&S Industries, Inc. recommends that you consult a bicycle specialist if you have any doubts or concerns as to your experience or ability to properly assemble, maintain or operate this product. To reduce risk of injury to adult and child rider, the Trail-Gator Bicycle Tow Bar must be properly fitted and adjusted to the adult and child bike and in good safe operating condition at all times. The adult and child rider is responsible to learn and understand the safe operation of the Trail-Gator Bicycle Tow Bar. Each rider must know, understand, and comply with all appropriate vehicle, bicycle, and traffic laws and also the rules of safe, common sense bicycling.

## Tow Bar Requirements

### Adult Bike

- Minimum tire diameter 25" (635mm)
- Seat post diameter 1" (25.4mm) - 1.25" (31.8mm)



Do not use on seat post diameters smaller than 1" (25.4mm) or failure may occur, which can cause serious injury to riders.

- Use of steel seat post is recommended.
- No accessories or equipment (racks, etc.) on rear that interfere with tow bar operations.

### Child Bike

- Rear free wheel capability required. (Bike capable of coasting without peddling)
- 12" (30.5cm) - 20" (50.8cm) tire diameter.
- No accessories or equipment (Baskets, etc.) on front of bike preventing clear access to head tube.

For center pull brakes, see kit # 10270

- If child uses training wheels they must store up out of the way or be removed when being towed.

For Trail-Gator Flip Up Training Wheels, see item # 10310



Do not use the tow bar with child bikes having training wheels in the down position as they prevent the child bike from leaning when cornering, and can cause serious injury to riders.

## Installation

- 1 Remove adult bike seat post.
- 2 Determine seat post diameter and shim (s) if needed. **A** Small Shim **B** Large Shim
- 3 Insert seat post through tow bar, facing gap in shim(s) to rear if used, and reinstall seat post.



Seat post must be inserted a minimum distance **C** into adult frame and seat post bolt must be tightened correctly to prevent risk of injury to riders.

Position tow bar close at frame, align to rear of adult bike and tighten bolts



Bolts **D** and **E** must be tightened 13 foot-pounds (17.6 Nm) to prevent risk of injury to riders.

- 4 Determine extended tow bar length. Hole **F** 14"-16" child bike, hole **G** 18"-20" child bike. Slide outer tube over inner tube, install pin **H** and latch.

- 5 Determine receiver assembly mounting position on child bike. 14"-16" child bike usually upper mount **5.1** or center mount **5.3**. 18"-20" child bike usually lower mount **5.2** or center mount **5.3**.

- 6 Install receiver hardware spacing distance between U-bolts **I** as far as possible, with curved portion of U-bolt facing outward away from each other **5.3** or with curved portion of U-bolt facing the same direction as each other **5.1** and **5.2**. Curved ears of receiver **J** face down. Do not face U-bolts with curved portion facing inward toward each other. Align to front of child bike and tighten.



U-bolt must be tightened 15 foot-pounds (20.4 Nm) to prevent risk of injury to riders.

### Adult Rider

- Rider of tow bicycle must be an adult.
- Adult rider must have good bicycle riding ability and skills.
- Adult rider must weigh at least twice that of child rider.
- Adult rider must wear a properly fitted and approved bicycle helmet.

### Child Rider

- Maximum child weight of 70 pounds.
- Child rider must have good basic bicycle riding skills.
- Child rider must be alert at all times keeping hands on handlebars, feet on pedals, and stay seated.
- Child rider must wear a properly fitted and approved bicycle helmet.

### Tools Required for Assembly

- 2 Adjustable Wrenches
- 1 Flat Head Screwdriver
- 1 Torque Wrench and 13mm Socket

- 7** Attach tow bar to child bike by lifting coupler **L** end of tow bar in one hand and lifting front of child bike with the other hand to position **7.1**. Slide coupler down, over receiver engaging them at curved ears **7.2**. Lower both tow bar and child bike, keeping upward force on child bike, until fully engaged **7.3**. Properly engaged, child bike front wheel is held above ground and coupler and receiver holes aligned for Quick Release installation.

Child bike front wheel must be 3"-5" (8 cm-13 cm) above ground **M** to prevent risk of injury to riders. See wheel height adjustment **10** if needed.



- 8** Insert Quick Release **N**, install adjusting nut **O** and lock.

- 9** **6mm and 8mm Quick Release Operation** To properly lock, place lever in open position **P** and hold, then Hand Tighten adjusting nut until it stops. Pivot lever to closed position. Halfway closed, there must be firm resistance for proper locking. If resistance is not firm, open lever and Hand Tighten adjusting nut clockwise. Pivot lever all the way to closed position **Q** and lock.

- 10** If needed, determine distance to raise or lower child bike front wheel.

Raise Wheel Height about 2" (5cm) moving receiver from upper mount **5.1** to lower mount **5.2** or about 3/4" (1.9cm) for each shim added between receiver and upper mounted U clamp, **10.1**.

Lower Wheel Height about 2" (5cm) moving receiver from lower mount **5.2** to upper mount **5.1** or about 3/4" (1.9cm) for each shim added between receiver and lower mounted U clamp, **10.2**.

- 11** To install receiver shim (s) **R** loosen all nuts, Do Not Remove, insert shim (s) where needed, between receiver **J** and U clamp **K**, align and tighten to specifications.



Failure to adjust receiver angle properly can result in child bike being too high above the ground or too low to ground and can cause serious injury to riders.

- 12** With child bike attached to tow bar, remove front wheel. Determine fork size and assembly needed.

7/8" Shim Set **S**, 1" Shim Set **T**, Oval Shim **U**, Small Fork Clamp **V**, Large Fork Clamp **W**.

- 13** Slide fork clamp up fork left side (right side optional) near top, facing bolt hole in fork clamp to rear, insert shim (s) if needed. Install ball socket bolt **X**, washer **Y** and binder nut **Z**, Hand Tighten Only. Reinstall front wheel and align steering straight. Align tube clamp **AA** and fork clamp so stabilizer rod **BB** will pivot down and snap to bolt **X** and tighten both clamps.



Bolt **CC** must be tightened 8 foot-pounds (10.8 Nm) and bolt **X** must be tightened 10 foot-pounds (13.5 Nm) to prevent risk of injury to riders.

- 14** Disconnect tow bar from child bike, slide to stored position, hole **DD**. Insert pin, and latch. Insert Quick Release into tow bar coupler for storage.

Warning, Excessive Quick Release clamping force may damage coupler end by collapsing it. Loosen left rear axle nut (right side optional). Place storage bracket **EE** between bike frame and axle nut **FF**, facing rear, Hand Tighten Only. Fold tow bar down to side, align storage bracket to receive tow bar, tighten rear axle nut and storage bracket assembly.

#### Operating Instructions

##### Using Tow Bar

1. Unclip tow bar from stored position.
2. Remove pin, extend to proper length, insert pin and latch.



Failure to place safety latch over end of pin can result in pin coming loose and can cause serious injury to riders

3. Remove Quick Release from coupler end of tow bar.
4. Hold tow bar coupler end in one hand and lift front of child bike with other hand. Slide coupler down over receiver, engaging them at curved ears. Lower both tow bar and child bike, keeping upward force on child bike, until fully engaged.
5. Insert Quick Release and lock.
6. Unclip stabilizer bar, pivot down and snap to front fork.

##### Storing Tow Bar

1. Unclip stabilizer bar from front fork by holding stabilizer bar with fingers and pushing against fork with your thumb.
2. Pivot stabilizer bar up to stored position and clip.
3. Remove Quick Release from coupler and receiver.
4. Hold tow bar coupler end in one hand and child bike in other hand. Lift both up, slightly pushing down on child bike until disengaged.
5. Insert Quick Release into coupler end of tow bar for storage. **Warning:** Excessive clamping force may damage coupler by collapsing it.
6. Remove pin, slide tow bar together, insert pin and latch.
7. Fold tow bar down to side and place into storage clip.

#### Mechanical Safety Check

Carry out the following safety checks before every ride:

##### Tow Bar

- Ensure all nuts and bolts are properly tightened.
- Ensure all parts of tow bar have no damage or cracks.
- Ensure all moving parts in universal joint have no wear.
- Ensure safety pin and tow bar holes are not worn or damaged and that they fit together without excessive play.
- Ensure coupler and receiver function properly and child bike is positioned properly, facing forward when attached.
- Ensure Quick Release functions properly.
- Ensure handlebar stabilizer assembly functions properly.
- Ensure all storage clips function properly.

##### Adult Bike

- Ensure seat post is not bent or cracked and is securely fastened into frame.
- Ensure front and rear brakes work properly.
- Ensure bike is in correct and safe working order. See adult bike Owner's Manual.

##### Child Bike

- Ensure head tube and frame of bike has no sign of damage.
- Ensure rear free wheel capability and brakes work properly.
- Ensure bike is in correct and safe working order. See child bike Owner's Manual.

### Rider Safety Check

- Riders must wear properly fitted and approved bicycle helmets.
- Never use off-road. Use only on smooth surfaces.
- Never exceed maximum child rider weight of 70 pounds.
- Do not ride on highways, in traffic, or on unsafe streets.
- Never exceed 15 miles per hour using tow bar.
- Never ride over bumps or curbs using tow bar.
- Avoid cornering near objects. Child bike will track closer to objects than adult bike.
- Never carry more than one child on child bike.
- Never use tow bar with a motorized bicycle or vehicle.
- Never use tow bar while carrying another child on adult bike.
- Adult rider must be thoroughly familiar with all operations and controls (steering, braking, and gears) of adult bike before using tow bar.
- You must allow for greater starting and stopping distances due to extra length and weight of child rider and child bike.
- Adult rider must steady and securely hold adult bike upright before allowing child to mount child bike.
- Never use when child is tired. Child must be alert and capable of staying seated, keeping hands on handlebars and feet on pedals at all times.
- Adult and child rider must wear shoes that are securely fastened onto feet and that provide an adequate grip to pedals. Never ride barefoot or with sandals.
- Riding at night is dangerous and should be avoided. Only ride at night with approved lighted system and correctly positioned reflectors on both bikes.

### Riding With Tow Bar

Locate a safe, flat, and level riding area with no traffic to become safely familiar with operation and feel of towing the child bike. First, attach tow bar and ride without towing a child on the child bike. Note how both bikes turn, lean and feel while riding, stopping and starting. Note how child bike tracks closer when turning than adult bike and requires a wider turn, when close to objects, in order to clear objects. Continue to ride with child bike unoccupied until you feel confident with your ability to safely operate stopping, starting and towing the child bike.

Still in a safe area away from traffic, hold adult bike in upright position and allow child to mount child bike. You must always hold child bike steady when child gets on. Begin riding with the child at a slow pace and continue to ride until you are confident of both your abilities and the child's abilities to safely operate each bike with tow bar attached.

Practice starting and stopping. Distances required will be much different than when you are riding alone. You must allow for extra weight and length when stopping and starting. Learn and understand these differences before attempting to use tow bar in general riding situations. It is important to teach the child to use brakes only when instructed before attempting general riding situations.

Once you are confident of your abilities and the child's abilities to safely use tow bar you can then use it for more general riding situations. Never use tow bar if you have any doubts about your ability or the child's ability to handle general riding situations.

### Service and Maintenance



All parts of tow bar and bicycles are subject to stress and wear and may require replacement after extended use to prevent failure. If a problem is noticed, discontinue use until problem is corrected.

Failure to correct a problem can cause serious personal injury to riders and death.

- Perform mechanical safety check before every ride.
- Look for scratches, cracks, bending and changes in color of metal or plastic which indicate fatigue or stress and replace worn parts.
- Break in period: All bolts, nuts, pins, and other components may stretch and require readjusting after first ten hours of use.
- Keep clean and free of dirt and water. Dirt and water can cause unit to wear prematurely and can cause corrosion which can reduce strength and life of the product.

### Limited Warranty

S & S Industries, Inc. warrants this product, to the original purchaser, to be free of defect in materials and workmanship for a period of one year from the date of purchase. This warranty is solely limited to the repair or replacement of defective parts and no transportation or labor is included.

This warranty does not apply to any product which has been improperly assembled, improperly maintained, subject to abuse or misuse, involved in accidents, or altered or repaired in any way. This warranty ceases when you rent, sell or give away the tow bar. Liability for consequential damages is excluded to the extent exclusion is permitted by law. This warranty gives you specific legal rights. Additional warranty rights may be provided by law in some areas.

To obtain warranty service, purchaser must return the defective components to the place of purchase or contact S & S Industries, Inc., Sarasota, FL, USA at 941-316-9763 for the repair or replacement, subject to the terms and conditions as described above.

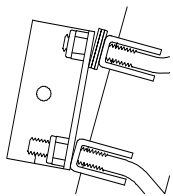

### Extra Receiver Kit # 10230

Sets up an additional child bike for towing. Kit contains receiver parts for child bike.

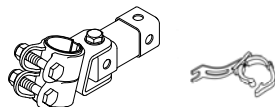

### Extra Seat Post Kit #10250

Adult riders can take turns towing a child bike by transferring tow bar from one adult bike to another adult bike. Kit contains seat post clamp, Quick Release and storage bracket assemblies. Colors: red, blue, black.

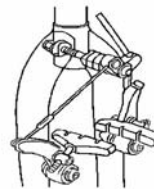

### Center Pull Brake Adapter Kit #10270

Allows tow bar to be fitted on child bike frames with center pull brakes. Kit offsets brake cable allowing receiver to mount on head tube.

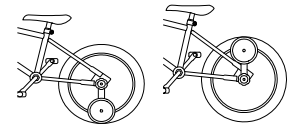

### Flip-Up Training Wheels #10310

Necessary for children who use training wheels. No tools required, a hand-tightened knob is used to flip wheels up for towing and down when child is riding on their own. Warning Training wheels must be flipped up or removed when using tow bar.

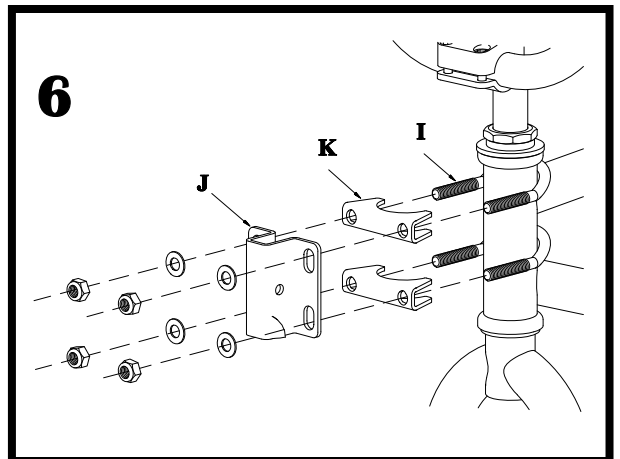
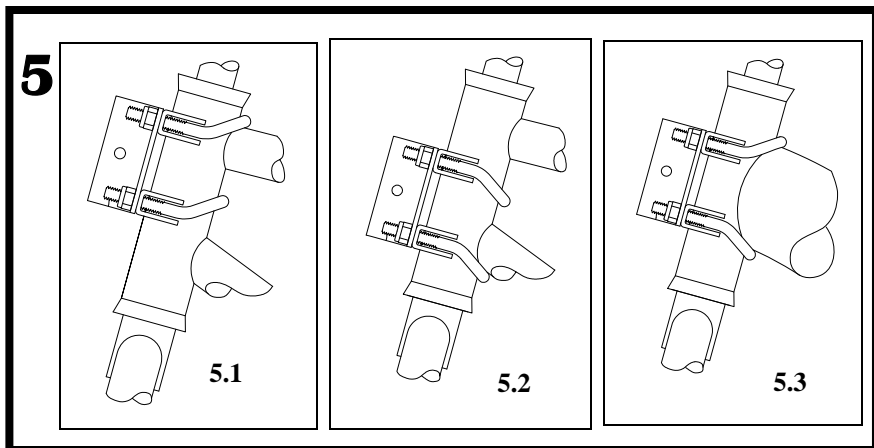
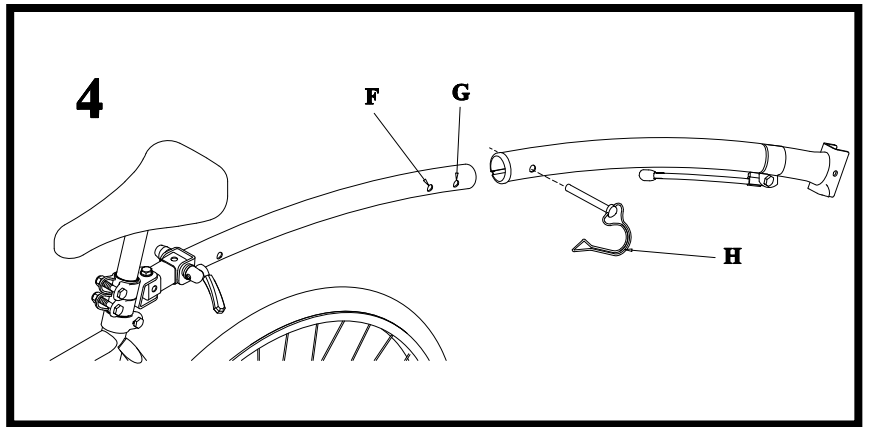
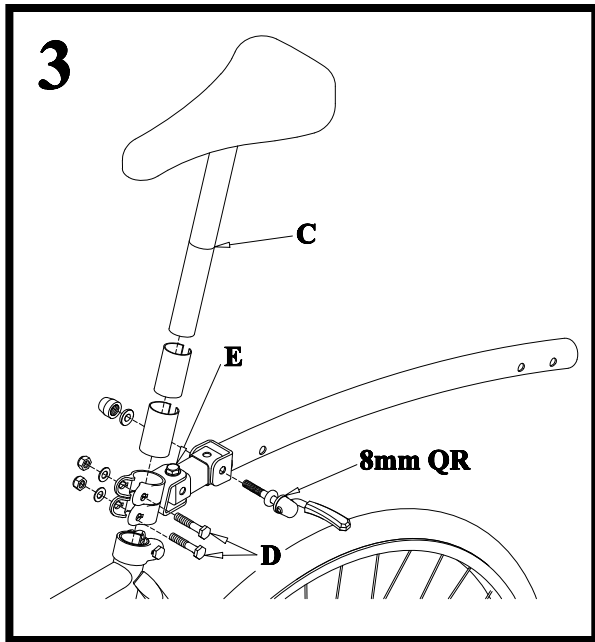
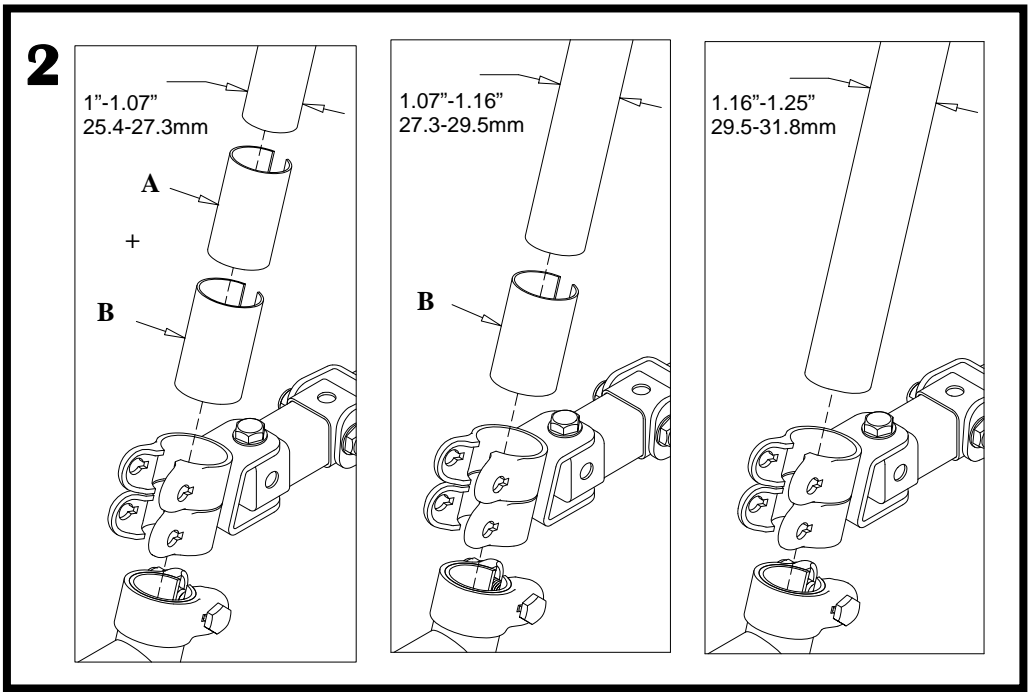
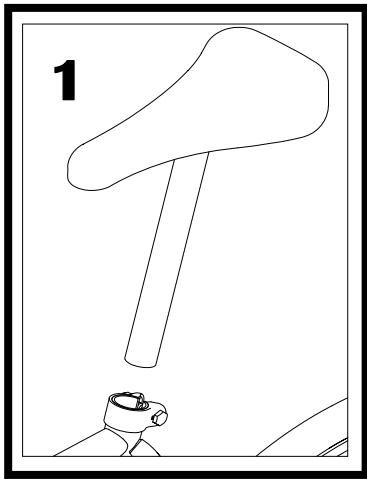

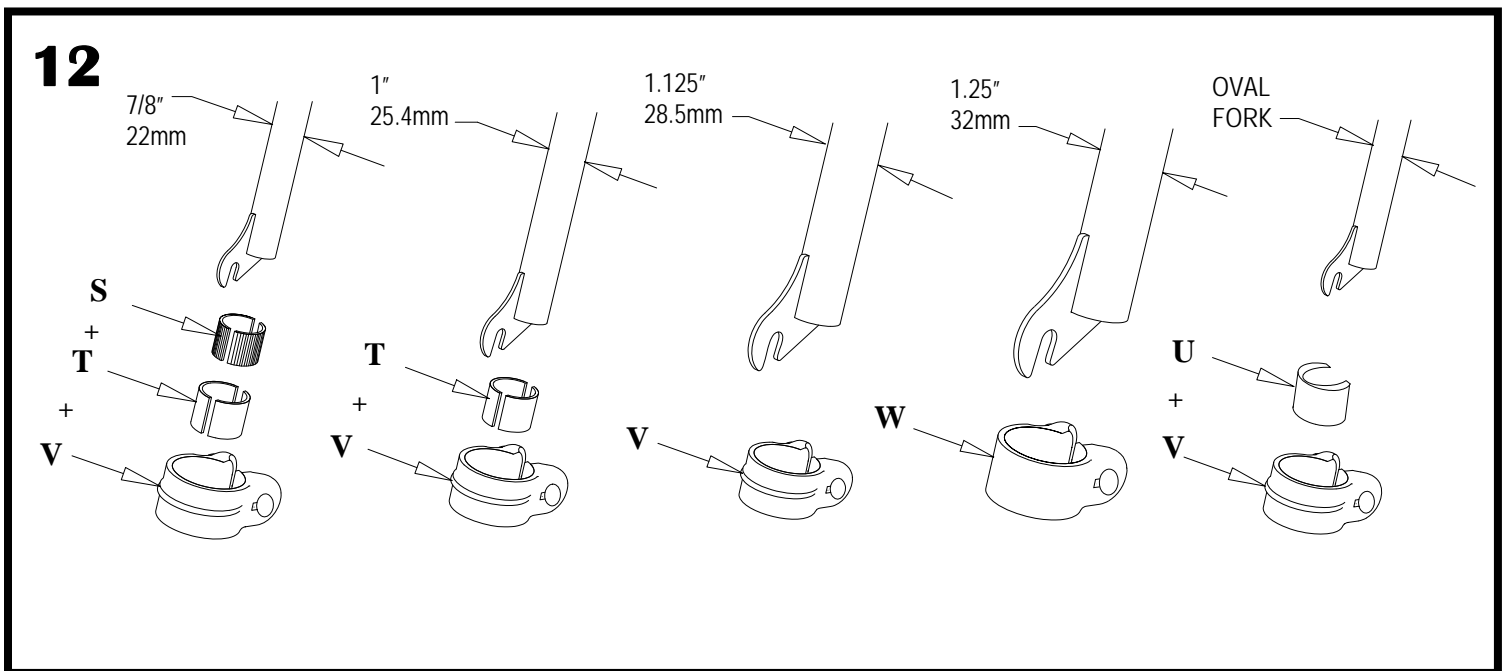
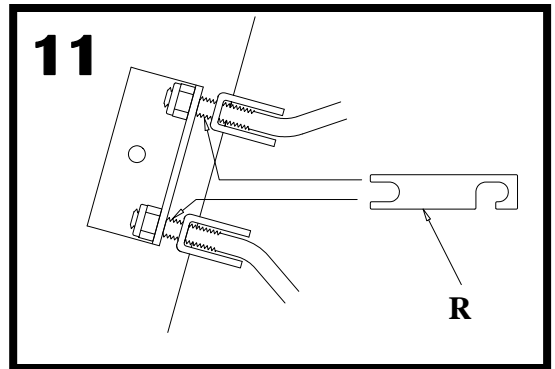
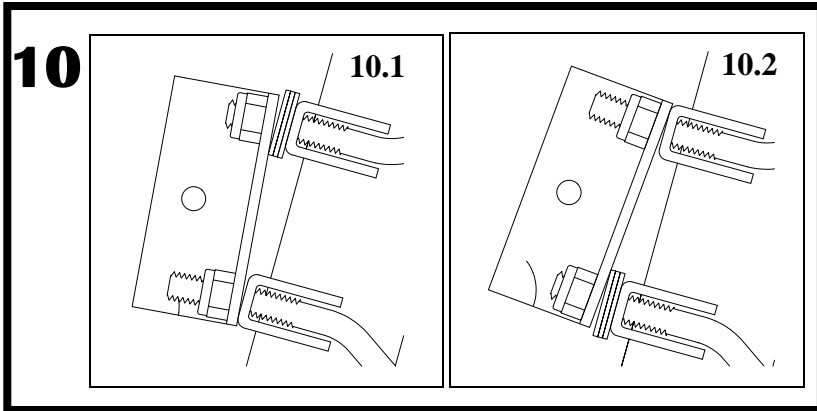
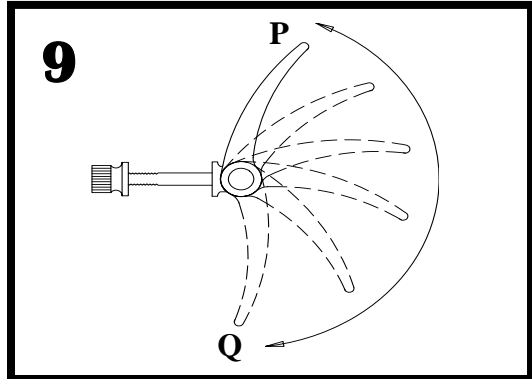
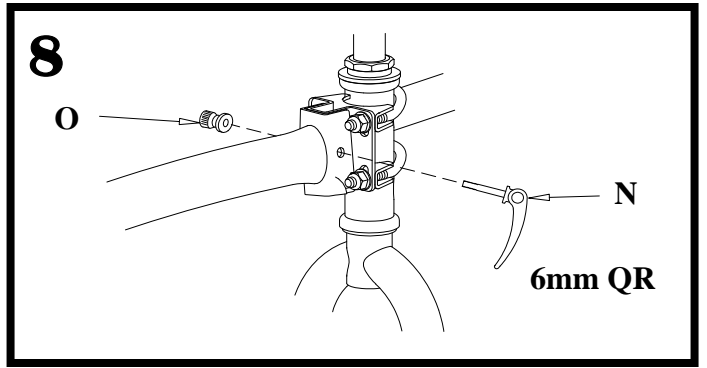
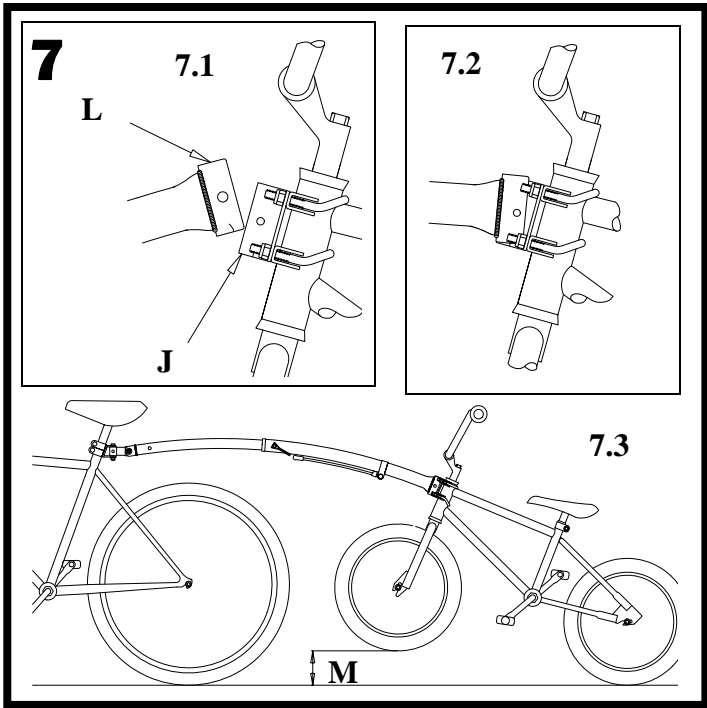

**13**

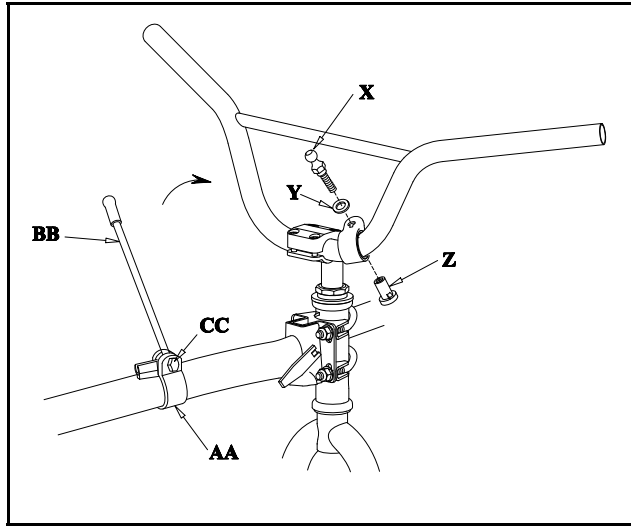
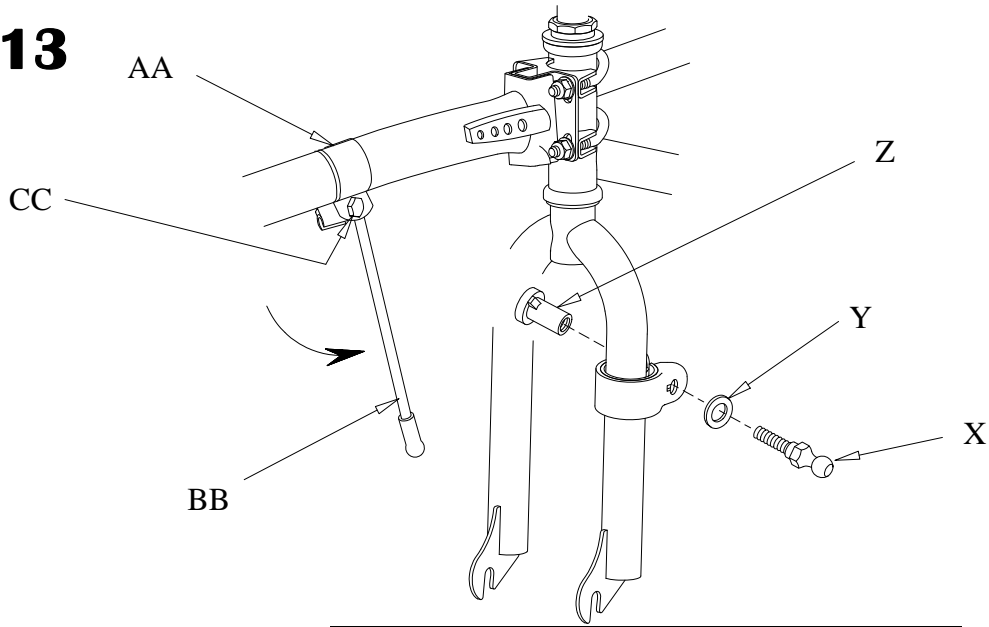

**14**

